

# LABY®-GI FUEL GAS COMPRESSOR SYSTEMS

## LUBRICATED AND NON-LUBRICATED SOLUTIONS FOR MAN ME-GI POWERED LNG CARRIERS

### **FULLY INTEGRATED COMPRESSOR SOLUTION**

Burckhardt Compression offers a variety of compressor solutions for fuel gas compression that have been specifically designed for marine applications. Our ME-GI fuel gas compressor systems are designed for BOG management on LNG carriers equipped with MAN ME-GI two-stroke engines.

The well-proven Laby®-GI Compressors offer a power-efficient solution for fuel gas compression and support the optimization of the ship's operational costs (OPEX). The fully balanced compressor system can supply gen-sets, the propulsion engine and the reliquefaction system. In addition, it can be operated in parallel to the pump vaporizer unit.

### **CUSTOMER BENEFITS OF LABY®-GI COMPRESSORS**

- Low power consumption leads to minimized operational costs (OPEX)
- Multi-purpose compression for ME-GI engines, gen-sets and PRS supply
- Unique piston sealing technology for maximum reliability and availability
- No major maintenance between dry docks necessary with lubricated high-pressure stages
- No oil contamination of cargo with non-lubricated high-pressure stages
- Ship's crew can perform onboard maintenance
- Full range of after-sales services available

# FULLY BALANCED FUEL GAS COMPRESSION

## DESIGN FEATURES

- Gas-tight crankcase for greater safety and zero gas loss
- Cryogenic operation without BOG pre-warming
- No vibrations due to elimination of unbalanced forces and moments
- Designed according to marine standards
- Available as non-lubricated compressor up to 310 bar

## PROCESS LAYOUT (NON-LUBRICATED)

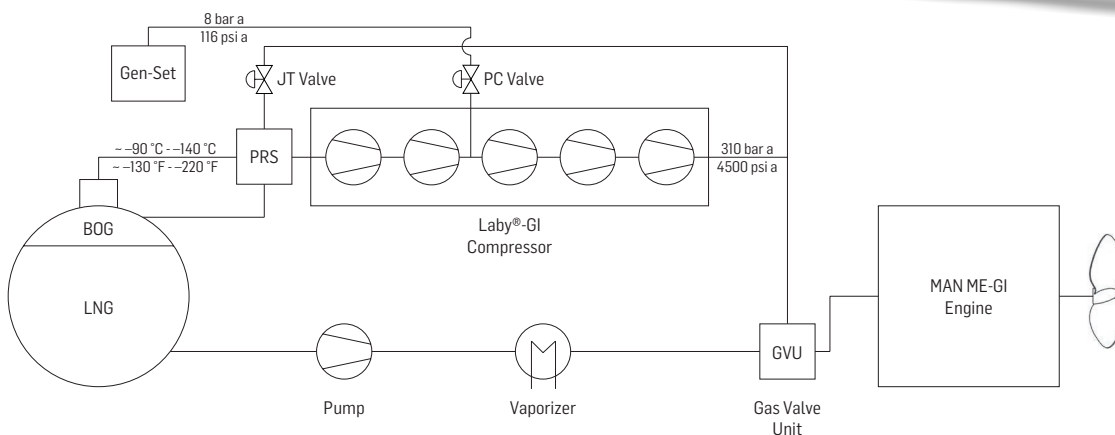
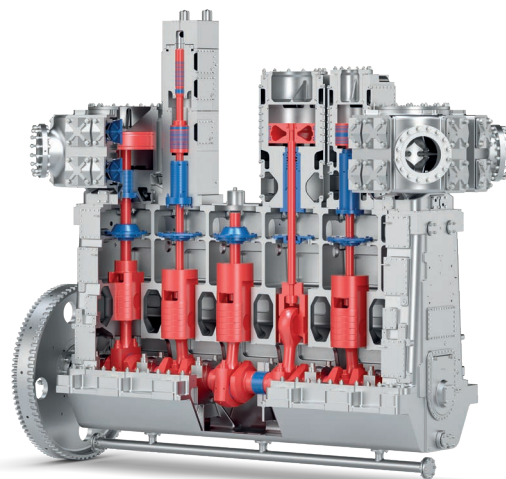

## TECHNICAL DATA

Type	Typical Mass Flow kg/h / lbs/h	Width mm / in	Height mm / in	Length mm / in	Weight kg / lbs
4LP250	< 4'500 / 9'900	7'000 / 275	5'000 / 200	13'000 / 510	127'000 / 280'000
4LP250-V	< 4'500 / 9'900	7'000 / 275	5'000 / 200	13'000 / 510	125'000 / 275'000
5LP250	< 5'200 / 11'500	7'000 / 275	5'000 / 200	13'000 / 510	137'000 / 302'000
5LP250-V	< 5'200 / 11'500	7'000 / 275	5'000 / 200	13'000 / 510	135'000 / 300'000
6LP250	< 6'000 / 13'200	7'000 / 275	5'000 / 200	13'000 / 510	157'000 / 345'000
6LP250-V	< 6'000 / 13'200	7'000 / 275	5'000 / 200	13'000 / 510	155'000 / 340'000

### Burckhardt Compression

24-hour emergency tel.: +41 52 262 53 53  
 info@burckhardtcompression.com  
 www.burckhardtcompression.com